

Model ESFR-17 Early Suppression, Fast Response Pendent Sprinklers 16.8 K-factor

General Description

The TYCO Model ESFR-17 Pendent Sprinklers are Early Suppression, Fast Response (ESFR) sprinklers with a nominal K-factor of 16.8. The sprinkler assembly is shown in Figure 1. They are suppression mode sprinklers that are especially advantageous as a means of eliminating in-rack sprinklers when protecting high-piled storage.

Model ESFR-17 Pendent Sprinklers are primarily used for ceiling-only sprinkler protection of, but not limited to, the following storage applications:

- Most encapsulated or non-encapsulated common materials including cartoned, unexpanded plastics
- Cartoned, expanded plastics
- Uncartoned, unexpanded plastics
- Uncartoned, expanded plastics
- Some storage arrangements of rubber tires, roll paper, and aerosols

For more specific criteria, see Table A and the applicable design standard.

The Model ESFR-17 Pendent Sprinklers provide the system designer with hydraulic and sprinkler placement options not presently available to traditional ESFR Sprinklers having a nominal K-factor of 14.0. In particular, Model ESFR-17 Pendent Sprinklers are designed to operate at substantially lower-end head pressures, as compared to ESFR Sprinklers having a nominal K-factor of 14.0. This feature

offers flexibility when sizing system piping, as well as possibly reducing or eliminating the need for a system fire pump.

NOTICE

The Model ESFR-17 Pendent Sprinklers described herein must be installed and maintained in compliance with this document, as well as with the applicable standards recognized by the Approval agency, in addition to the standards of any authorities having jurisdiction, such as FM Global. Failure to do so may impair the performance of these devices.

The owner is responsible for maintaining their fire protection system and devices in proper operating condition. Contact the installing contractor or product manufacturer with any questions.

In all cases, the appropriate NFPA or FM installation standard, or other applicable standard, must be referenced to ensure applicability and to obtain complete installation guidelines. The general guidelines in this data sheet are not intended to provide complete installation criteria.

Sprinkler Identification Number (SIN)

See Table A



Technical Data

Approvals

FM Approved
VdS Approved
LPCB Approved (094b and 0071)
NYC under MEA 356-01-E

Finish

Natural Brass

Physical Characteristics

Frame	Brass
Deflector	Bronze
Compression Screw	Stainless Steel
Hook	Monel
Strut	Monel
Link Assembly	Solder, Nickel
Button	Brass
Sealing Assembly ..	Beryllium Nickelw/TEFLON
Ejection Spring	Inconel
Deflector Nut	Brass

Additional Technical Data

See Table A

IMPORTANT

Refer to Technical Data Sheet TFP2300 for warnings pertaining to regulatory and health information.

Always refer to Technical Data Sheet TFP700 for the "INSTALLER WARNING" that provides cautions with respect to handling and installation of sprinkler systems and components. Improper handling and installation can permanently damage a sprinkler system or its components and cause the sprinkler to fail to operate in a fire situation or cause it to operate prematurely.

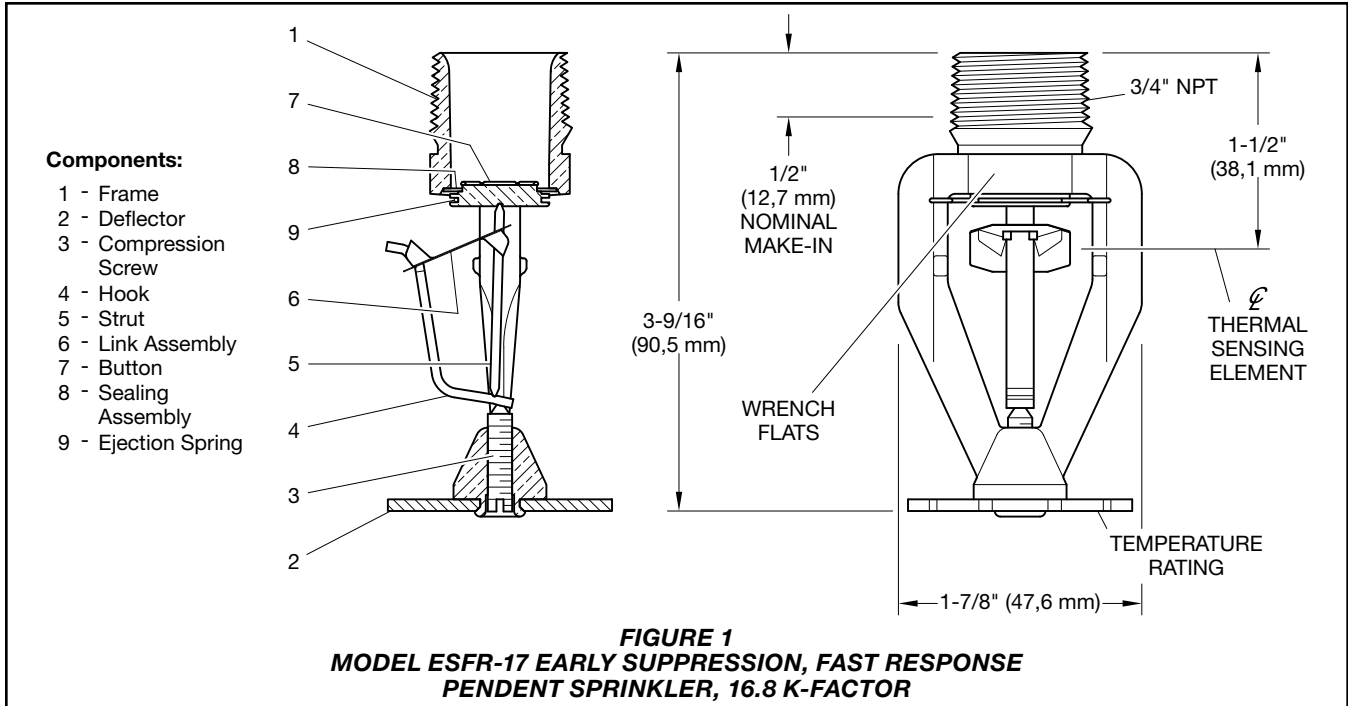

Operation

The fusible link assembly is comprised of two link halves that are joined together by a thin layer of solder. When the rated temperature is reached, the solder melts and the two link halves separate, activating the sprinkler and flowing water.

Item	Description
Sprinkler Identification Number (SIN)	TY7226
K-factor, (gpm/psi ^{1/2}) (Lpm/bar ^{1/2})	16.8 gpm/psi ^{1/2} (241,9 Lpm/bar ^{1/2})
Temperature Rating °F (°C)	165°F (74°C) 212°F (100°C)
Thread Size	3/4 in. NPT or ISO 7-R 3/4
Sprinkler Orientation	Pendent
Maximum Working Pressure, psi (bar)	175 psi (12,1 bar)

TABLE A
MODEL ESFR-17 PENDENT SPRINKLER
TECHNICAL DATA

Design Criteria

The following general guidelines provided for the TYCO Model ESFR-17 Pendent Sprinklers can be used for a quick reference.

The National Fire Protection Association (NFPA) and FM Global (FM) provide installation standards that must be used to properly design an automatic sprinkler system utilizing Early Suppression, Fast Response (ESFR) Sprinklers. The guidelines provided by NFPA and FM may differ; consequently, the appropriate standard must be used for a given installation. See Table B for additional information.

In all cases, the appropriate NFPA or FM installation standard must be referenced to ensure applicability and to obtain complete installation guidelines, since the following general guidelines are not intended to provide complete installation criteria. For more information, see Table B.

Roof Construction

Unobstructed or obstructed construction, such as smooth ceiling, bar joists, beam and girder.

Where the depths of the solid structural members, such as beams and stem, exceed 12 in. (302 mm), install ESFR Sprinklers in each channel formed by the structural members.

Ceiling Slope

Maximum 2 in. rise for 12 in. run (16.7%)

Maximum Coverage Area

100 ft² (9,3 m²)

Minimum Coverage Area

64 ft² (5,8 m²)

per NFPA 13 and FM Global 2-0

Maximum Spacing

- 12 ft (3,7 m) for building heights up to 30 ft (9,1 m)
- 10 ft (3,1 m) for building heights greater than 30 ft (9,1 m)

Note: In some cases, installation standards permit a greater spacing.

Minimum Spacing

8 ft (2,4 m)

Minimum Clearance to Commodity

36 in. (914 mm)

NFPA Deflector-to-Ceiling Distance

6 in. to 14 in. (152 mm to 356 mm)

FM Global

Centerline of Thermal Sensing

Element-to-Ceiling Distance

Refer to FM Global 2-0 for Storage Sprinklers.

Storage Type	FM Global
Sprinkler Type	Storage
Response Type	QR
System Type	Wet
Temperature Rating °F (°C)	165°F (74°C) 212°F (100°C)
Open Frame (i.e., no solid shelves) Single, Double, Multiple-Row, or Portable Rack Storage of Class I-IV and Group A or B Plastics	Refer to FM 2-0 and 8-9
Solid Pile or Palletized Storage of Class I-IV and Group A or B Plastics	Refer to FM 2-0 and 8-9
Idle Pallet Storage	Refer to FM 2-0, 8-9, and 8-24
Rubber Tire Storage	Refer to FM 2-0 and 8-3
Roll Paper Storage (Refer to the Standard)	Refer to FM 8-21
Flammable/Ignitable Liquid Storage (Refer to the Standard)	Refer to FM 7-29
Aerosol Storage (Refer to the Standard)	Refer to FM 7-31
Automotive Components in Portable Racks (Control mode only; refer to the Standard)	N/A
N/A – Not Applicable	

TABLE B
MODEL ESFR-17 PENDENT SPRINKLERS
COMMODITY SELECTION AND DESIGN CRITERIA OVERVIEW

Installation

The TYCO Model ESFR-17 Pendent Sprinklers must be installed in accordance with this section.

General Instructions

Avoid damage to the fusible Link Assembly during installation by using only the Frame arms to handle the sprinkler and by using the appropriate sprinkler wrench. Do not apply pressure to the fusible Link Assembly. Failure to do so can lead to an unstable link assembly and premature activation of the sprinkler. Damaged sprinklers must be replaced.

A leak-tight 3/4 in. NPT sprinkler joint should be obtained by applying a minimum-to-maximum torque of 10 to 20 lb-ft (13,4 to 26,8 N·m). Higher levels of torque can distort the sprinkler inlet with consequent leakage or impairment of the sprinkler.

Step 1. Install the Model ESFR-17 Pendent Sprinkler in the pendent position, see Figure 2.

Step 2. With pipe-thread sealant applied, hand-tighten the sprinkler into the sprinkler fitting. Do not apply pressure to the Link Assembly, and handle the Model ESFR-17 Sprinkler only by the Frame arms.

Step 3. Wrench-tighten the Model ESFR-17 Sprinkler using only the W-Type 21 Sprinkler Wrench as shown in Figure 2, and by fully engaging (seating) the wrench on the sprinkler wrench flats as shown in Figure 1.

Step 4. After installation, inspect the Link Assembly of each Model ESFR-17 Sprinkler for damage. In particular, verify that the Link Assembly and Hook are positioned as shown in Figure 1, and that the Link Assembly is not bent, creased, or forced out of normal position in any way. Replace damaged sprinklers.

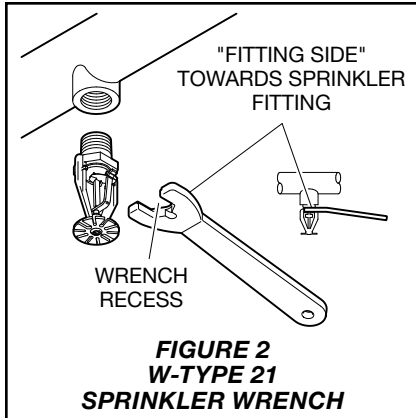

Care and Maintenance

The TYCO Model ESFR-17 Sprinklers must be maintained and serviced in accordance with this section.

Before closing a fire protection system main control valve for maintenance work on the fire protection system that it controls, permission to shut down the affected fire protection system must be obtained from the proper authorities and notify all personnel who may be affected by this action.

Sprinklers which are found to be leaking or exhibiting visible signs of corrosion must be replaced.

Automatic sprinklers must never be painted, plated, coated, or otherwise altered after leaving the factory. Modified sprinklers must be replaced. Sprinklers that have been exposed to corrosive products of combustion, but have not operated, should be replaced if they cannot be completely cleaned by wiping the sprinkler with a cloth or by brushing it with a soft bristle brush.

Care must be exercised to avoid damage to the sprinklers before, during, and after installation. Sprinklers damaged by dropping, striking, wrench twist/slippage, or the like, must be replaced. Also, replace any sprinkler that has a cracked bulb or that has lost liquid from its bulb. For more information, see the Installation section.

The owner is responsible for the inspection, testing, and maintenance of their fire protection system and devices in compliance with this document, as well as with the applicable standards of the National Fire Protection Association, such as NFPA 25, in addition to the standards of any authorities having jurisdiction. Contact the installing contractor or product manufacturer with any questions.

Automatic sprinkler systems are recommended to be inspected, tested, and maintained by a qualified Inspection Service in accordance with local requirements and/or national codes.

Limited Warranty

For warranty terms and conditions, visit www.tyco-fire.com.

Ordering Procedure

Contact your local distributor for availability. When placing an order, indicate the full product name and Part Number (P/N).

Sprinkler Assemblies

Specify: Model ESFR-17 (TY7226), K=16.8, Early Suppression, Fast Response Pendent Sprinkler with (specify) temperature rating, natural brass, P/N (specify):

165°F (74°C) 58-445-1-165
212°F (100°C) 58-445-1-214

Special Order Sprinkler Assemblies with ISO 7-1 Thread Connections

Specify: Model ESFR-17 (TY7226), K=16.8, Early Suppression, Fast Response Pendent Sprinkler with ISO 7-1 thread connection, (specify) temperature rating, natural brass, P/N (specify):

165°F (74°C) 58-446-1-165
212°F (100°C) 58-446-1-214

Sprinkler Wrench

Specify: W-Type 21 Sprinkler Wrench, P/N 56-001-0-686