

RAPID RESPONSE Residential Dry Pipe System

General Description

The TYCO RAPID RESPONSE Residential Dry Pipe System provides a normally dry system for areas subject to freezing or areas that may be inadvertently subject to freezing.

The key components of the RAPID RESPONSE Residential Dry Pipe System are:

- Model RCP-1 Residential Control Panel
- RAPID RESPONSE Residential Sprinklers specifically Listed for use in residential dry pipe systems (versus being limited to wet pipe systems only)
- TYCO CPVC Pipe and Fittings made with BLAZEMASTER Compound
- SprinkFDT Fluid Delivery Calculation Software

Typically, residential sprinklers based on their Listing are limited to wet pipe sprinkler systems to assure speed of water delivery for a prescribed design area (the number of design sprinklers). The Model RCP-1 Residential Control Panel, in combination with specific Rapid Response Residential Sprinklers listed for use in dry pipe systems, provides options for areas sensitive to freezing.

IMPORTANT

Refer to Technical Data Sheet TFP2300 for warnings pertaining to regulatory and health information.

Always refer to Technical Data Sheet TFP700 for the "INSTALLER WARNING" that provides cautions with respect to handling and installation of sprinkler systems and components. Improper handling and installation can permanently damage a sprinkler system or its components and cause the sprinkler to fail to operate in a fire situation or cause it to operate prematurely.

To achieve UL Listing, the RAPID RESPONSE Residential Sprinklers have undergone rigorous testing to meet UL1626 fire test criteria, including a 15-second delay for water delivery as required for residential sprinklers intended for use in dry pipe systems.

NOTICE

The Rapid Response Residential Dry Pipe System described herein must be installed and maintained by qualified personnel in compliance with this document, and with the applicable standards of the NATIONAL FIRE PROTECTION ASSOCIATION (NFPA), in addition to the requirements of any other authorities having jurisdiction. Failure to do so may impair the performance of this device.

The owner is responsible for maintaining their fire protection system and devices in proper operating condition and in compliance with all applicable standards and requirements. Contact the installing contractor or product manufacturer with any questions.

Do not disconnect batteries or turn off AC power to quiet unwanted alarms.

The Model RCP-1 Panel will not operate (that is, release water or energize alarms) if AC power is not connected, has failed, or has been interrupted for any reason and the battery is disconnected, drained, or improperly connected.

The use of an automatic sprinkler system does not allow for omission of a Household Fire Alarm System installed per NFPA 72. The Model RCP-1 Panel is not intended to be used as part of a Household Fire Alarm System.

Disconnect electrical field power when making any internal adjustments or repairs. Failure to do so may result in personal injury. Servicing should be performed by qualified personnel.

Static electricity can damage components. Therefore, qualified personnel must be grounded before opening components, installing components, and prior to installation. Keep components wrapped in anti-static material at all times.

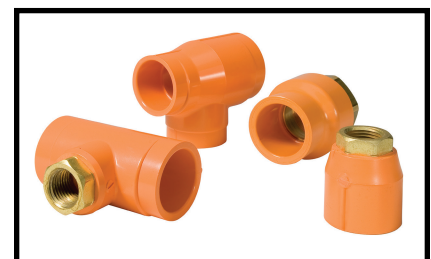

This equipment generates, uses, and can radiate radio frequency energy, and if not installed and used in accordance with this technical data sheet, may cause interference to radio communications. This equipment has been tested and found to comply with the limits for a Class A computing device pursuant to Subpart J of Part 15 of FCC Rules, that are designed to provide reasonable protection against such interference when operated in a commercial environment. However, operation of this equipment in a residential area may cause interference, in which case the user, at their own expense, will be required to take whatever measure may be required to correct the interference.

To ensure proper operation, this product must be retested by qualified personnel in accordance with the Care and Maintenance section after any modification, repair, or adjustment. Retesting is required to assure that the system is operating as intended.

Model RCP-1 Residential Control Panel

A key component of the Residential Dry Pipe System is The Model RCP-1 Panel.

The Model RCP-1 Residential Control Panel is an integrated valve manifold, air pressure, and electronic control package for controlling the release of water into residential dry pipe sprinkler systems.

The Model RCP-1 Panel is intended for use in one-and two-family dwellings and mobile homes per NFPA 13D when used with residential sprinklers that have been Listed for use in dry pipe residential sprinkler systems.

The Model RCP-1 Panel incorporates the Listed Model 4004R Household Fire Warning Unit Subassembly installed within the Model RCP-1 Panel cabinet.

The Model RCP-1 Panel includes the following features:

- Pre-wired assembly containing pre-programmed control panel, system performance gauges, and an enclosed compressor
- Pre-engineered riser design
- Supervised valve system
- High pressure supervision for indication of a false trip or failure of the automatic air supply cut-out switch
- Dry contacts for remote connection (dial-up systems or additional monitoring, for example)
- 48-hour battery backup

For detailed information about the Model RCP-1 Panel, refer to Technical Data Sheet TFP480.

RAPID RESPONSE Residential Sprinklers

The Residential Dry Pipe System operates with RAPID RESPONSE Residential Sprinklers. These wet and dry-type residential sprinklers have undergone rigorous testing to meet UL1626 fire test criteria, including a 15-second delay for water delivery as required for residential sprinklers intended for use in dry pipe systems.

TYCO CPVC Pipe and Fittings

Another component of the Residential Dry Pipe System is TYCO BLAZEMASTER CPVC Pipe and Fittings. TYCO CPVC products provide the only complete line of BLAZEMASTER pipe and fittings in the fire protection industry and are also UL Listed for use in dry pipe systems.

⚠ WARNINGS

Never remove any piping component or correct or modify any piping deficiencies without first de-pressurizing and draining the system. Failure to do so may result in equipment damage and/or personal injury.

SprinkFDT Fluid Delivery Calculation Software

Water delivery times can be conveniently determined prior to actual field installations using the industry's only fluid delivery calculation software, the TYCO SprinkFDT program.

For more information on this fluid delivery calculation program, visit www.sprinkcad.com.

Technical Data

Approvals

The Model RCP-1 Residential Control Panel is UL Listed for use in residential dry pipe systems installed in one- and two- family dwellings and mobile homes per NFPA 13D when installed in accordance with this document.

The Model 4004R Household Fire Warning Unit Subassembly (Electronic Control) installed with the Model RCP-1 cabinet is UL and C-UL Listed.

The following sprinklers are UL Listed for use in residential dry pipe sprinkler systems:

- TY1334: 4.2K Sidewall/Recessed Sidewall
- TY2234: 4.9K Pendent/Recessed Pendent
- TY2234: 4.9K Domed Concealed Pendent
- TY2235: 4.9K Dry-Type Recessed Pendent
- TY3596: Concealed Pendent Sprinkler, Flat Plate

TYCO CPVC Pipe and Fittings are UL Listed for use in residential dry pipe systems.

Sprinkler Selection and Piping

To prevent potential freezing of water in most applications, and in order to ensure complete draining of the system after a hydrostatic test, trip test, or system operation, see Figure 4 for appropriate sprinkler selection and piping arrangements.

NOTICE

The referenced data sheets provide complete descriptions of these sprinklers, including installation criteria for wet pipe systems. As a function of their UL Listing for use in residential dry pipe systems, the following criteria provides Water Delivery and Hydraulic Design criteria as it relates to the sprinkler's use in dry pipe systems:

- TY1334: Data Sheet TFP410
- TY2234: Data Sheet TFP400
- TY2234: Data Sheet TFP450
- TY2235: Data Sheet TFP460
- TY3596: Data Sheet TFP442

Design Criteria

The following design criteria is provided with respect to residential sprinklers, sprinkler pipe and fittings, water delivery, and notification appliances.

Residential Sprinklers

NOTICE

The use of an automatic sprinkler system does not allow for omission of a Household Fire Alarm System installed per NFPA 72.

Sprinklers are to be located and hydraulically designed per their Listing for use in dry pipe systems.

See Tables A to D for required flows and pressures for residential dry pipe listings. In accordance with NFPA 13D, sprinkler types and/or piping configurations supplying these sprinklers vary depending on factors such as temperature, type of piping, and water supply. See Figure 4 for appropriate sprinkler selection and piping arrangements.

CPVC Pipe and Fittings

Corrosion-resistant or internally galvanized pipe must be utilized with the sprinklers described in this data sheet.

TYCO BLAZEMASTER CPVC Pipe and Fittings have been specifically listed for use in dry systems. Users must be familiar with and follow listing parameters, such as, maximum 15 psi (1,0 bar) air pressure when utilizing CPVC products in a dry-type system.

To facilitate draining, piping in areas subject to freezing shall be pitched in accordance with NFPA 13D for dry pipe systems.

The TYCO CPVC Sprinkler Head Adapter Tee (P/N 80259) is to be used with the dry-type residential pendent sprinklers in dry pipe system installations.

Refer to the TYCO technical manual CPVC Fire Sprinkler Products Installation Instructions & Technical Handbook (IH-1900).

Water Delivery

For dry pipe systems, the requirements for Dry System Water Delivery per Section 8.3.4.3 of the 2010 edition of NFPA 13D applies. Water delivery to the most remote single sprinkler for a residential hazard shall not exceed 15 seconds. The use of the TYCO SprinkFDT Fluid Delivery calculation program is recommended to assure a properly operating system can be achieved prior to constructing the actual installation.

Figures 1 and 2 provide a sample sprinkler layout and water delivery times that can be expected for a dry pipe sprinkler system.

As an alternative to using a Listed water delivery calculation program and method as referenced in NFPA 13D, an inspector's test connection providing a flow equivalent to the smallest orifice sprinkler may be utilized, wherein the test orifice is located on the end of the pipe supplying the most remote sprinkler.

NOTICE

In no case shall the time of water delivery exceed 15 seconds for the most remote operating sprinkler.

Hydraulic Design (NFPA 13D)

The minimum required sprinkler flow rates for systems designed to NFPA 13D (dry systems) are given in Tables A to F as a function of temperature rating and the maximum allowable coverage areas. The sprinkler flow rate is the minimum required discharge from each of the total number of design sprinklers (the two most hydraulically demanding sprinklers) as specified in NFPA 13D.

Notification Appliances

NOTICE

NFPA 13D does not require the installation of a waterflow alarm (notification appliance device).

Notification appliances can be installed to indicate release of the Model RCP-1 Panel.

When installed, notification appliances must be installed in accordance with the applicable requirements of NFPA 72. Per the requirements of NFPA 72, fire warning equipment for dwelling units shall provide a sound that is audible in all occupiable dwelling areas.

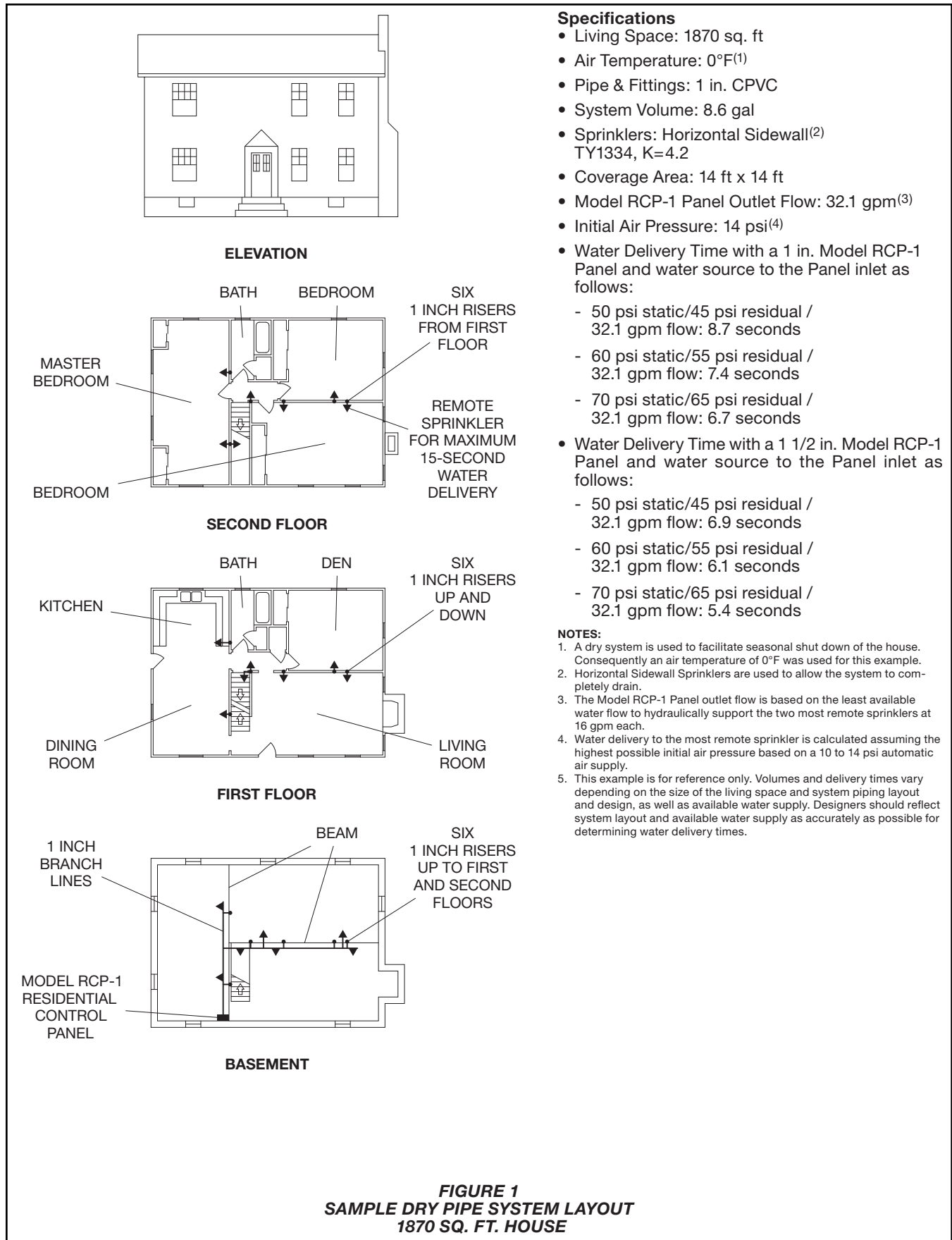



ELEVATION

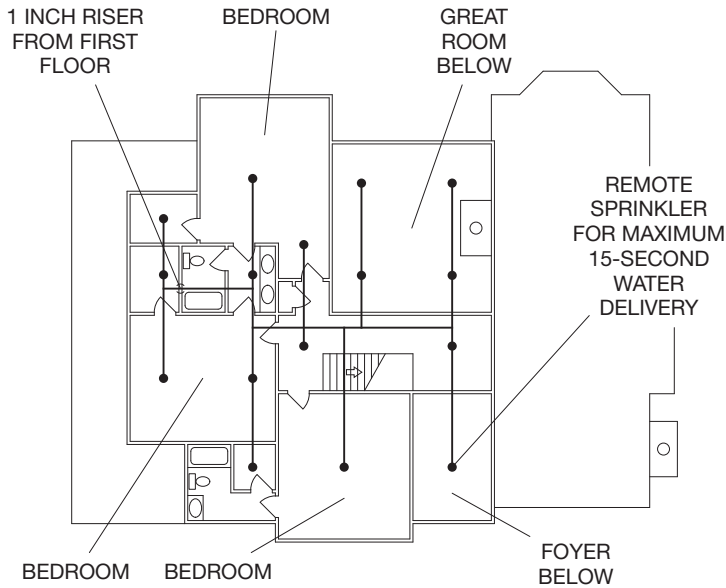

SECOND FLOOR

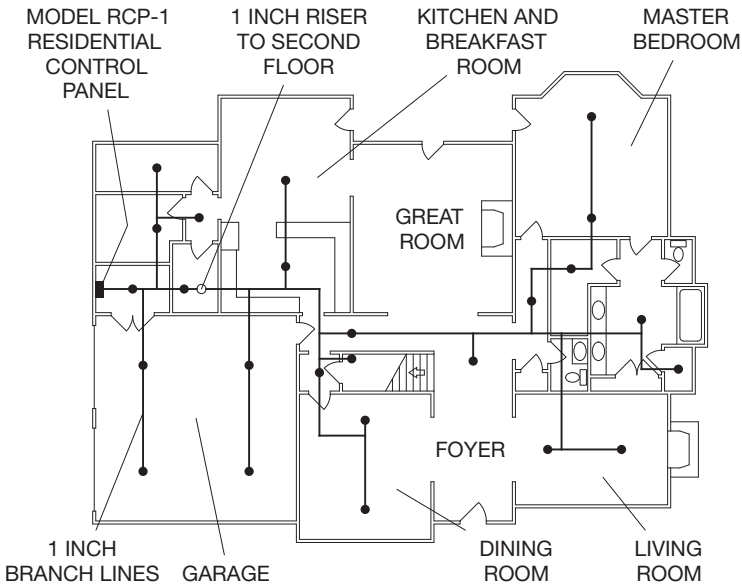

FIRST FLOOR

Specifications

- Living Space: 3480 sq. ft
- Air Temperature: 0°F⁽¹⁾
- Pipe & Fittings: 1 in. CPVC
- System Volume: 18.6 gal
- Sprinklers: Pendent⁽²⁾
TY2235, K=4.9
- Coverage Area: 16 ft x 16 ft
- Model RCP-1 Panel Outlet Flow: 30.5 gpm⁽³⁾
- Initial Air Pressure: 14 psi⁽⁴⁾
- Water Delivery Time with a 1 in. Model RCP-1 Panel and water source to the Panel inlet as follows:
 - 50 psi static/45 psi residual / 30.5 gpm flow: 13.7 seconds
 - 60 psi static/55 psi residual / 30.5 gpm flow: 12.1 seconds
 - 70 psi static/65 psi residual / 30.5 gpm flow: 11.1 seconds
- Water Delivery Time with a 1 1/2 in. Model RCP-1 Panel and water source to the Panel inlet as follows:
 - 50 psi static/45 psi residual / 30.5 gpm flow: 12.8 seconds
 - 60 psi static/55 psi residual / 30.5 gpm flow: 11.6 seconds
 - 70 psi static/65 psi residual / 30.5 gpm flow: 10.7 seconds

NOTES:

1. A dry system is used to facilitate seasonal shut down of the house. Consequently an air temperature of 0°F was used for this example.
2. Dry-Type Residential Pendent Sprinklers.
3. The Model RCP-1 Panel outlet flow is based on the least available water flow to hydraulically support the two most remote sprinklers at 15 gpm each.
4. Water delivery to the most remote sprinkler is calculated assuming the highest possible initial air pressure based on a 10 to 14 psi automatic air supply.
5. This example is for reference only. Volumes and delivery times vary depending on the size of the living space and system piping layout and design, as well as available water supply. Designers should reflect system layout and available water supply as accurately as possible for determining water delivery times.

FIGURE 2
SAMPLE DRY PIPE SYSTEM LAYOUT
3480 SQ. FT. HOUSE

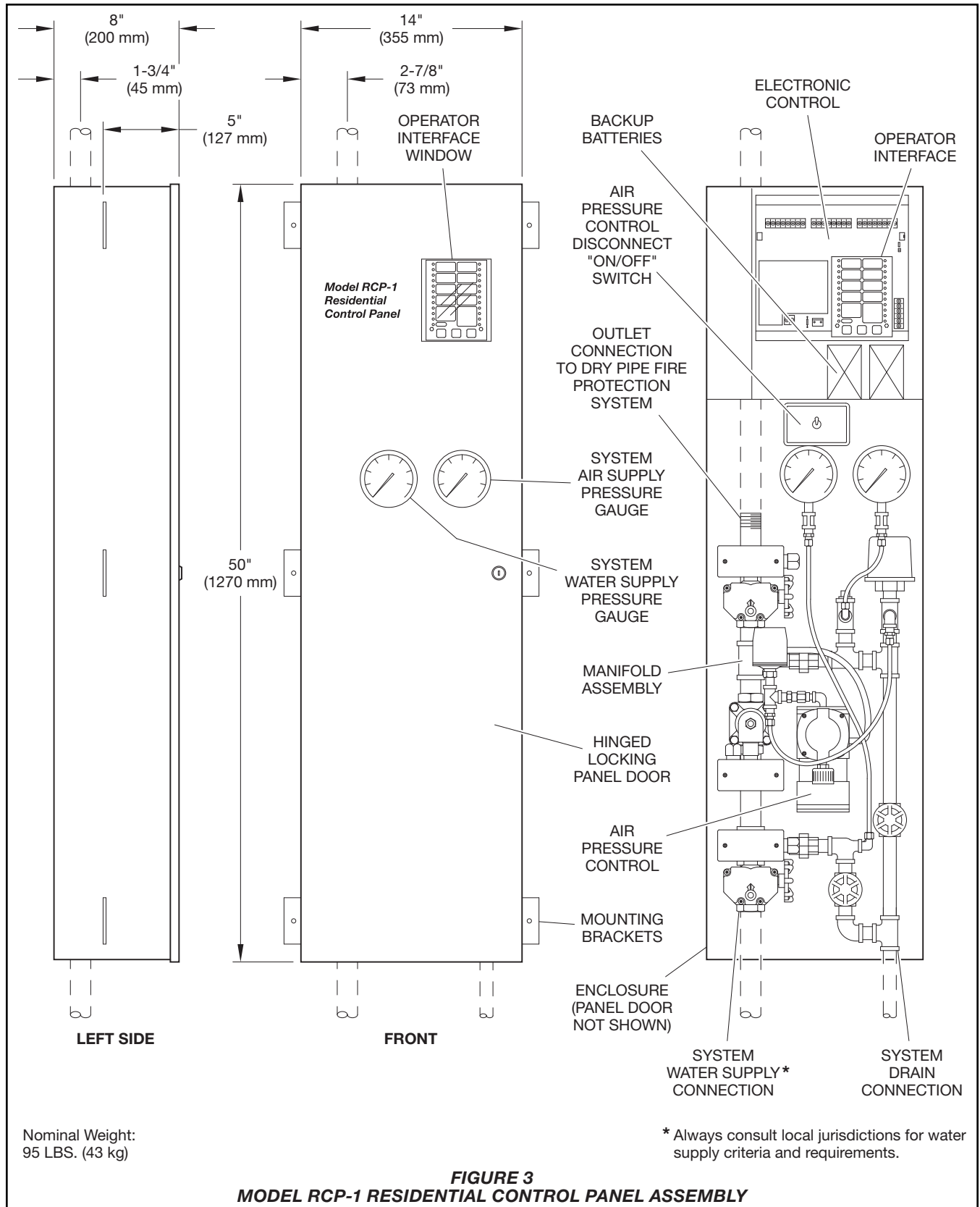

Nominal Weight:
 95 LBS. (43 kg)

* Always consult local jurisdictions for water supply criteria and requirements.

FIGURE 3
MODEL RCP-1 RESIDENTIAL CONTROL PANEL ASSEMBLY

CPVC and Copper Pipe					Steel Pipe (Internally Galvanized for Residential Dry Pipe Systems)				
Residential Sprinkler Type	Potable Water		Non-Potable Water		Residential Sprinkler Type	Potable Water		Non-Potable Water	
	Ambient Temperature		Ambient Temperature			Ambient Temperature		Ambient Temperature	
	< 40°F (< 4,4°C)	≥ 40°F (≥ 4,4°C)	< 40°F (< 4,4°C)	≥ 40°F (≥ 4,4°C)		< 40°F (< 4,4°C)	≥ 40°F (≥ 4,4°C)	< 40°F (< 4,4°C)	≥ 40°F (≥ 4,4°C)
Pendent (a)	N/A	✓ Example 2	N/A	✓ Example 1	Pendent (a)	N/A	✓ Example 1	N/A	✓ Example 1
Sidewall (b)	✓ Example 3	✓	✓ Example 3	✓	Sidewall (b)	✓ Example 3	✓	✓ Example 3	✓
Dry-Type Pendent (c)	✓ Example 4	✓	✓ Example 4	✓	Dry-Type Pendent (c)	✓	✓	✓	✓

a. Recessed Pendent, TY2234; Data Sheet TFP400
 Domed Concealed Pendent TY2234; Data Sheet TFP450
 Flat Plate Concealed Pendent, TY3596; Data Sheet TFP442

b. Recessed Horizontal Sidewall, TY1334; Data Sheet TFP410
 c. Dry-Type Recessed Pendent, TY2235; Data Sheet TFP460

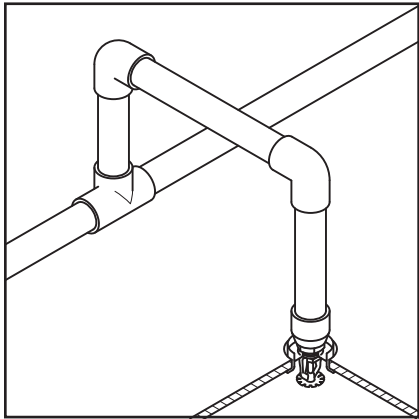

**EXAMPLE 1
 RETURN
 BEND**

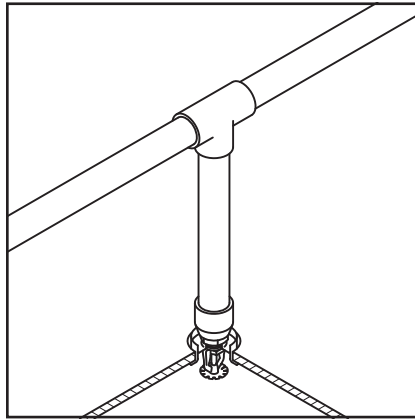

**EXAMPLE 2
 NO RETURN BEND
 REQUIRED**

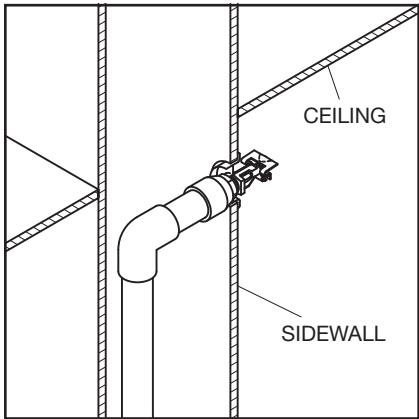

**EXAMPLE 3
 SIDEWALL
 (NO TRAPPING OF WATER)**

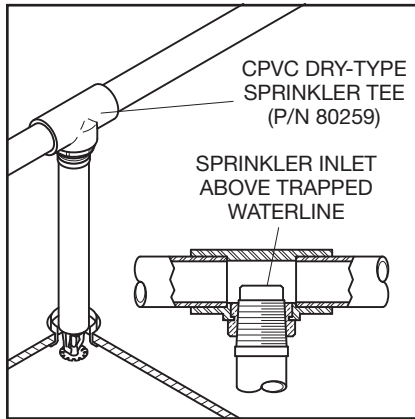

**EXAMPLE 4
 DRY PENDENT USING CPVC TEE
 FOR DRY SYSTEMS**

**FIGURE 4
 SPRINKLER CONFIGURATIONS FOR RESIDENTIAL DRY PIPE SYSTEMS
 PER NFPA 13D**



Maximum Coverage Area ^(a) ft x ft (m x m)	Maximum Spacing ft (m)	DRY PIPE Minimum Flow ^(b) and Residual Pressure for Horizontal Ceiling (Maximum 2 in. Rise for 12 in. Run)	
		155°F (68°C)	175°F (79°C)
12 x 12 (3,7 x 3,7)	12 (3,7)	13 gpm (49,2 Lpm) 7.0 psi (0,48 bar)	13 gpm (49,2 Lpm) 7.0 psi (0,48 bar)
14 x 14 (4,3 x 4,3)	14 (4,3)	14 gpm (53,0 Lpm) 8.2 psi (0,57 bar)	14 gpm (53,0 Lpm) 8.2 psi (0,57 bar)
16 x 16 (4,9 x 4,9)	16 (4,9)	15 gpm (56,8 Lpm) 9.4 psi (0,65 bar)	15 gpm (56,8 Lpm) 9.4 psi (0,65 bar)
18 x 18 (5,5 x 5,5)	18 (5,5)	18 gpm (68,1 Lpm) 13.5 psi (0,93 bar)	18 gpm (68,1 Lpm) 13.5 psi (0,93 bar)
20 x 20 (6,1 x 6,1)	20 (6,1)	21 gpm (79,5 Lpm) 18.4 psi (1,27 bar)	21 gpm (79,5 Lpm) 18.4 psi (1,27 bar)

Note:

- a. For coverage area dimensions less than or between those indicated, use the minimum required flow for the next highest coverage area for which hydraulic design criteria are stated.
- b. The Minimum Flow requirement is based on minimum flow in gpm (Lpm) from each sprinkler. The associated residual pressures are calculated using the nominal K-factor. Refer to Hydraulic Design under the Design Criteria section of TFP400.
- * For detailed information about the Series LFII Residential Pendant Sprinklers, refer to Technical Data Sheet TFP400.

TABLE A
RAPID RESPONSE SERIES LFII (TY2234)
4.9K RESIDENTIAL PENDENT AND RECESSED PENDENT SPRINKLERS
DRY PIPE SYSTEM NFPA 13D HYDRAULIC DESIGN CRITERIA



Maximum Coverage Area ^(a) ft x ft (m x m)	Maximum Spacing ft (m)	DRY PIPE Minimum Flow ^(b) and Residual Pressure for Horizontal Ceiling (Maximum 2 in. Rise for 12 in. Run)	
		155°F (68°C)	
12 x 12 (3,7 x 3,7)	12 (3,7)	13 gpm (49,2 Lpm) 7.0 psi (0,48 bar)	
14 x 14 (4,3 x 4,3)	14 (4,3)	14 gpm (53,0 Lpm) 8.2 psi (0,57 bar)	
16 x 16 (4,9 x 4,9)	16 (4,9)	15 gpm (56,8 Lpm) 9.4 psi (0,65 bar)	
18 x 18 (5,5 x 5,5)	18 (5,5)	20 gpm (75,7 Lpm) 16.7 psi (1,15 bar)	
20 x 20 (6,1 x 6,1)	20 (6,1)	22 gpm (83,3 Lpm) 20.2 psi (1,39 bar)	

Notes:

- a. For coverage area dimensions less than or between those indicated, it is necessary to use the minimum required flow for the next highest coverage area for which hydraulic design criteria are stated.
- b. The Minimum Flow requirement is based on minimum flow in gpm (Lpm) from each sprinkler. The associated residual pressures are calculated using the nominal K-factor. Refer to Hydraulic Design under the Design Criteria section of TFP450.
- * For detailed information about the Series LFII Residential Domed Plate Concealed Sprinklers, refer to Technical Data Sheet TFP450.

TABLE B
RAPID RESPONSE SERIES LFII (TY2234)
4.9K RESIDENTIAL DOMED PLATE CONCEALED SPRINKLERS
DRY PIPE NFPA 13D HYDRAULIC DESIGN CRITERIA



Maximum Coverage Area ^(a) ft x ft (m x m)	Maximum Spacing ft (m)	DRY PIPE Minimum Flow ^(b) and Residual Pressure for Horizontal Ceilings (Maximum 2 in. Rise for 12 in. Run)
		Recessed Pendant (TY2235)
		155°F (68°C)
12 x 12 (3,7 x 3,7)	12 (3,7)	13 gpm (49,2 Lpm) 7.0 psi (0,48 bar)
14 x 14 (4,3 x 4,3)	14 (4,3)	14 gpm (52,9 Lpm) 8.2 psi (0,57 bar)
16 x 16 (4,9 x 4,9)	16 (4,9)	15 gpm (56,8 Lpm) 9.4 psi (0,65 bar)
18 x 18 (5,5 x 5,5)	18 (5,5)	18 gpm (68,1 Lpm) 13.5 psi (0,93 bar)
20 x 20 (6,1 x 6,1)	20 (6,1)	21 gpm (79,5 Lpm) 18.3 psi (1,3 bar)

The CPVC Sprinkler Head Adapter Tee (P/N 80259) must be used when connecting a Dry-Type Residential Pendant Sprinkler to CPVC piping in areas subject to freezing.

Notes:

- a. For coverage area dimensions less than or between those indicated, use the minimum required flow for the next highest coverage area for which hydraulic design criteria are stated.
- b. The requirement is based on minimum flow in gpm (Lpm) from each sprinkler. The associated residual pressures are calculated using the nominal K-factor. Refer to Hydraulic Design under the Design Criteria section in TFP460.
- * For detailed information about the Series LFII Dry-Type Residential Pendant Sprinklers, refer to Technical Data Sheet TFP460.

TABLE C
RAPID RESPONSE SERIES LFII (TY2235)
4.9K DRY-TYPE RESIDENTIAL PENDENT SPRINKLERS
DRY PIPE SYSTEM NFPA 13D HYDRAULIC DESIGN CRITERIA

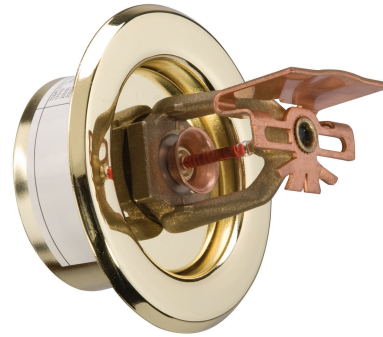

ELEVATION

Maximum Coverage Area ^(a) Width x Length ^(b) ft x ft (m x m)	Maximum Spacing ft (m)	DRY PIPE Minimum Flow ^(c) and Residual Pressure			
		Top-of-Deflector to Ceiling: 4 to 6 in. (100 to 150 mm)		Top-of-Deflector to Ceiling: 6 to 12 in. (100 to 150 mm)	
		155°F (68°C)	175°F (79°C)	155°F (68°C)	175°F (79°C)
12 x 12 (3,7 x 3,7)	12 (3,7)	12 gpm (45,4 Lpm) 8.2 psi (0,57 bar)	12 gpm (45,4 Lpm) 8.2 psi (0,57 bar)	13 gpm (49,2 Lpm) 9.6 psi (0,48 bar)	13 gpm (49,2 Lpm) 9.6 psi (0,48 bar)
14 x 14 (4,3 x 4,3)	14 (4,3)	16 gpm (60,6 Lpm) 14.5 psi (1,00 bar)	16 gpm (60,6 Lpm) 14.5 psi (1,00 bar)	18 gpm (68,1 Lpm) 18.4 psi (1,27 bar)	18 gpm (68,1 Lpm) 18.4 psi (1,27 bar)
16 x 16 (4,9 x 4,9)	16 (4,9)	16 gpm (60,6 Lpm) 14.5 psi (1,00 bar)	16 gpm (60,6 Lpm) 14.5 psi (1,00 bar)	18 gpm (68,1 Lpm) 18.4 psi (1,27 bar)	21 gpm (79,5 Lpm) 25.0 psi (1,72 bar)
16 x 18 (4,9 x 5,5)	16 (4,9)	19 gpm (71,9 Lpm) 20.5 psi (1,41 bar)	Not Applicable	21 gpm (79,5 Lpm) 25.0 psi (1,72 bar)	21 gpm (79,5 Lpm) 25.0 psi (1,72 bar)
16 x 20 (4,9 x 6,1)	16 (4,9)	23 gpm (87,1 Lpm) 30.0 psi (2,07 bar)	Not Applicable	Not Applicable	Not Applicable

Sidewall sprinklers, where installed under a ceiling with a slope greater than 0 in. rise for a 12 in. run to a slope up to a 2 in. rise for a 12 in. run, must be located per one of the following:

- At the high point of the slope and positioned to discharge down the slope.
- Along the slope and positioned to discharge across the slope.

Notes:

- a. For coverage area dimensions less than or between those indicated, use the minimum required flow for the next highest coverage area for which hydraulic design criteria are stated.
- b. The Width x Length dimension refers to Width (backwall where sprinkler is located) times Length (horizontal throw of sprinkler).
- c. The Minimum Flow Requirement is based on minimum flow in gpm (Lpm) from each sprinkler. The associated residual pressures are calculated using the nominal K-factor. Refer to Hydraulic Design under the Design Criteria section of TFP410.

* For detailed information about the Series LFII Residential Horizontal Sidewall Sprinklers, refer to Technical Data Sheet TFP410.

TABLE D
RAPID RESPONSE SERIES LFII (TY1334)
4.2K RESIDENTIAL HORIZONTAL SIDEWALL AND RECESSED HORIZONTAL SIDEWALL
SPRINKLERS DRY PIPE SYSTEM NFPA 13D HYDRAULIC DESIGN CRITERIA FOR HORIZONTAL CEILINGS
(MAXIMUM 2 INCH RISE FOR 12 INCH RUN)

Operator Interface

The Model RCP-1 Panel uses LEDs and keys as its primary means of displaying status information and controlling the system. It allows the occupants to monitor the status of the Model RCP-1 Panel and its circuits.

The Operator Interface is organized with the LEDs located along the left and right sides and keys along the lower edge, see Figure 5.

LEDs

- **ALARM LEDs**
A flashing red LED adjacent to the Sprinkler (IDC1) indicates an alarm.

- **TROUBLE LEDs**
A flashing yellow TROUBLE LED for one of the IDCs, NACs, or RACs indicates the presence of a circuit break or ground within a system point, or somewhere in the wiring between the control panel and one of its points.
- **SUPERVISORY**
A flashing yellow SUPERVISORY LED indicates a problem with the condition of the sprinkler system controls or normal status (for example, closed valve position for main control valve, closed valve position for system control valve, or high air condition).
- **SYSTEM TROUBLE**
When a trouble occurs, the SYSTEM TROUBLE LED flashes until accepted. When accepted, it changes from flashing to steady.
- **AC POWER**
When lit steady, the green AC POWER LED indicates the electronic control is receiving AC power that is within the specified range. If the LED is not lit and the panel is still functioning, electronic control is using battery power to operate. The cause for loss of AC Power should be determined and corrected. The system is in a normal standby condition when only the Green AC POWER LED is ON.

- **SYSTEM RELEASED**
The red SYSTEM RELEASED LED turns on steady when the RAC circuit is activated. Activation of the RAC circuit energizes the Solenoid Valve to permit water to enter the sprinkler system piping. RAC1 is utilized, and RAC2 is spare.
- **EARTH FAULT**
The yellow Earth Fault LED turns on steady when there is a wiring fault from circuit to Earth.
- **LAMP TEST**
A lamp (LED) test can be performed by pressing and holding the ACCEPT SIGNAL key for a duration of five seconds. Performing a lamp test lights all LEDs on the system and allows verification that all system LEDs are functioning.

KEYS

- **ACCEPT SIGNAL**
The system LEDs (ALARM, SUPERVISORY, and TROUBLE) flash to indicate the presence of an unaccepted alarm, supervisory, or trouble condition somewhere in the system. The ACCEPT SIGNAL key acknowledges the presence of an alarm, supervisory, or trouble condition. By momentarily pressing the ACCEPT SIGNAL key, the flashing LED turns steady. The ACCEPT SIGNAL key is used to acknowledge every abnormal status present in the system. For example, if there are two red alarms and three yellow troubles, the ACCEPT SIGNAL key must be pressed five times. The panel's tone-alert (piezo) turns off when all abnormal conditions are accepted.
- **SIGNAL SILENCE**
Pressing the SIGNAL SILENCE key silences the audible notification devices (horns). The yellow Alarm Silenced LED lights to indicate that an alarm is still active even if the audible alarms have been silenced.
- **SYSTEM RESET**
Pressing the SYSTEM RESET key directs the panel to reset all attached devices and clear all accepted alarms, troubles, and supervisory conditions. All alarms must first be accepted via the ACCEPT SIGNAL key and all devices must be reset (normal system air pressure re-established).

Note: After pressing the SYSTEM RESET key, the panel requires approximately fifteen seconds to clear.

Operation

The system is automatically maintained at a normal system air pressure of 10 to 14 psi (0,7 to 1,0 bar) via the Air Compressor. In the standby condition, water is prevented from entering the

Panel Reference	Name	Description
IDC	Initiating Device Circuit	Low Air Pressure
NAC	Notification Appliance Circuit	Optional Notification Appliance
RAC	Releasing Appliance Circuit	Solenoid Valve
SPM	Special Purpose Monitor	Main Control Valve Closure, System Control Valve Closure, or High System Air Pressure

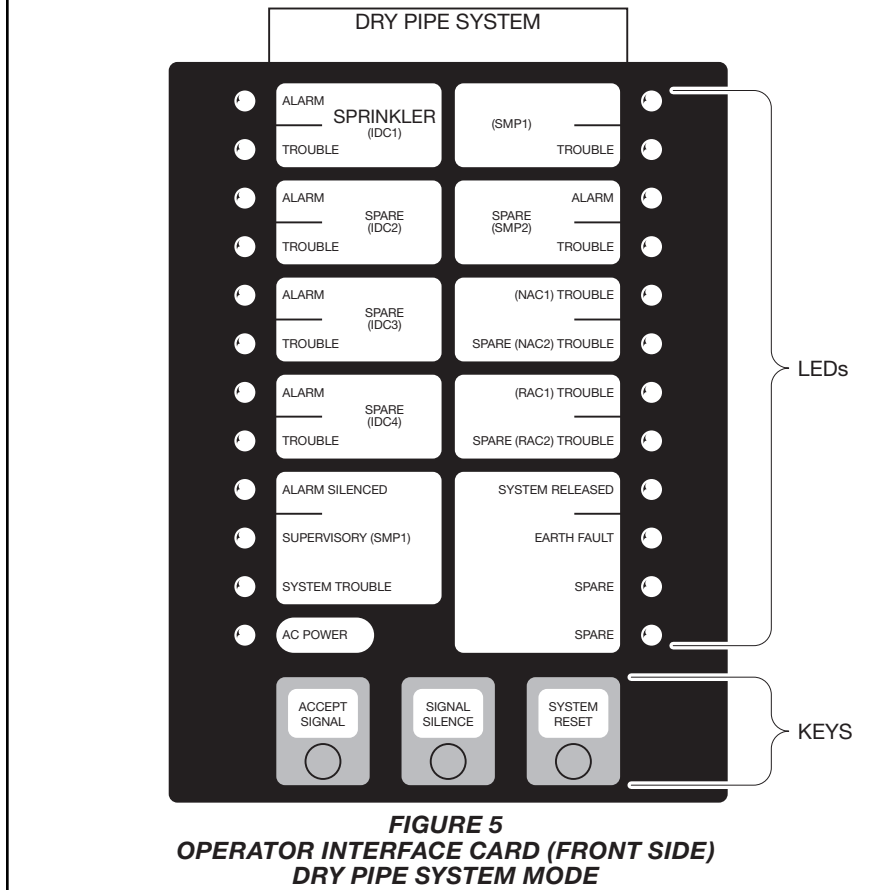

FIGURE 5
OPERATOR INTERFACE CARD (FRONT SIDE)
DRY PIPE SYSTEM MODE

system piping until the Solenoid Valve in the Manifold Assembly is opened in response to the electronic control.

Operation sequence:

- The normal standby condition is AC green light ON.
- Closure of Main Control Valve, closure of System Control Valve, or a high system pressure condition results in a supervisory condition (SPM1).

During a Supervisory Condition, the Yellow SUPERVISORY LED flashes and the tone-alert sounds steady. After accepting, the tone-alert silences and the Yellow SUPERVISORY LED stays on until the condition clears.

- Opening of a sprinkler results in a low air condition of less than nominally 8 psi (0,6 bar) resulting in an alarm condition on IDC1,

opening of the Solenoid Valve (RAC1), and operation of alarm notification devices (NAC1).

During an Alarm Condition, the Red ALARM LED, corresponding to Zone or SPM in alarm, flashes and the tone-alert pulses. After accepting, the tone-alert silences and the Red ALARM LED stays on until the alarm condition clears.

During a Trouble Condition, the yellow Trouble LED, corresponding to the zone or SPM with a trouble condition, flashes and the tone-alert sounds steady. After accepting, the tone-alert silences and the Red ALARM LED stays on until the alarm condition clears.

In Case of Supervisory/Trouble Condition

Step 1. Verify that a fire condition does not exist.

Step 2. Close the Main Control Valve to prevent inadvertent water flow into the system.

Step 3. Acknowledge the supervisory/trouble notification by momentarily pressing the ACCEPT SIGNAL key. Doing so silences the tone-alert.

Step 4. Determine and correct the cause of the supervisory/trouble notification. Examples of causes can be the following:

- Loss of primary 120 VAC power
- Low battery condition
- High air pressure
- Closure of the System or Main Control Valve

Step 5. Reset the system as soon as possible.

In Case of Alarm Condition

Step 1. Verify that a fire condition exists and take appropriate action (that is, evacuate the building and call fire department).

Step 2. After the fire is extinguished, reset the system.

If a fire condition does not exist and prior to resetting the system, silence alarms as follows:

- First, momentarily press the ACCEPT SIGNAL key a sufficient number of times to stop the tone-alert.
- Second, momentarily press the SIGNAL SILENCE key.

System Resetting

Step 1. Use the ACCEPT SIGNAL key to accept every abnormal status present in the system.

For example, when two red ALARM and three yellow TROUBLE conditions are present, the ACCEPT SIGNAL key must be pressed five times. The panel's tone-alert turns off when all abnormal conditions are accepted.

Step 2. Silence alarms by pressing the SIGNAL SILENCE key.

Step 3. Close the Main Control Valve.

Step 4. Place the Air Pressure Control Disconnect Switch to the OFF position.

Step 5. Open the Drain and Flow Test Valves.

Step 6. Replace operated sprinklers.

Step 7. After the system drains completely, close the Drain and Flow Test Valves.

Step 8. Place the Air Pressure Control Disconnect Switch to the ON position and allow the system to automatically reestablish its normal air pressure of 10 to 14 psi.

Step 9. Reset the Electronic Control by pressing the SYSTEM RESET key.

Wait approximately fifteen seconds for the Electronic Control to clear.

A supervisory signal will remain because the Main Control Valve is still closed.

Press the ACCEPT SIGNAL key to accept the supervisory signal and silence the tone-alert.

Step 10. Open the Main Control Valve.

The supervisory signal should clear and the system is now set for service.

Installation

TYCO Sprinklers and CPVC Pipe and Fittings are to be installed in accordance with their applicable data sheets.

The Rapid Response Model RCP-1 Residential Control Panel described herein must be installed and maintained in compliance with TFP480, as well as with the applicable standards of the NATIONAL FIRE PROTECTION ASSOCIATION, in addition to the requirements of any other authorities having jurisdiction. Failure to do so may impair the performance of this device.

NOTICE

Do not attempt to reprogram the Model RCP-1 Panel. If assistance is required, contact Technical Services at Johnson Controls.

Remove resistors only when instructed to do so. Failure to do so may lead to improper conditions or failure of the Model RCP-1 Panel to function properly.

The cover is electrically bonded to the enclosure ground terminal by means of an 18 AWG conductor. Do not remove the electrical bond.

Do not place any wiring in contact with CPVC pipe and fittings. Plasticizers, such as those found in flexible

wire insulation, can damage the pipe and fittings through contact resulting in damage/failure to the system.

Care and Maintenance

The following inspection/test procedure for the Rapid Response Model RCP-1 Residential Control Panel must be performed as indicated, in addition to any specific requirements of the NFPA. Any impairment must be immediately corrected.

Before closing a fire protection system control valve for inspection or maintenance work on the fire protection system that it controls, obtain permission to shut down the effected fire protection system from the proper authorities and notify all personnel who may be affected by this action.

The following inspection/test procedures will result in operation of the associated alarms. Notify the proper authorities and advise those responsible for monitoring proprietary and/or central station alarms.

After placing a fire protection system in service, notify the proper authorities and advise those responsible for monitoring proprietary and/or central station alarms.

TYCO Sprinklers and CPVC Pipe and Fittings are to be inspected and maintained in accordance with their applicable data sheets.

Owners are responsible for the inspection, testing, and maintenance of their fire protection system and devices in compliance with this document, as well as with the applicable standards of the NATIONAL FIRE PROTECTION ASSOCIATION, such as NFPA 25, in addition to the requirements of any authority having jurisdiction. The installing contractor or product manufacturer should be contacted relative to any questions.

Automatic sprinkler systems are recommended to be inspected, tested, and maintained by a qualified Inspection Service in accordance with local requirements and/or national codes.

Model RCP-1 Panel Inspection/Test Procedure

The Model RCP-1 Panel can be inspected and tested without having to flow water into the system piping. The inspection and testing, in accordance with the requirements of NFPA 25, must be performed annually.

General System Inspection/Test

Step 1. Verify the Air Pressure Gauge indicates a system air pressure of 10 to 14 psi.

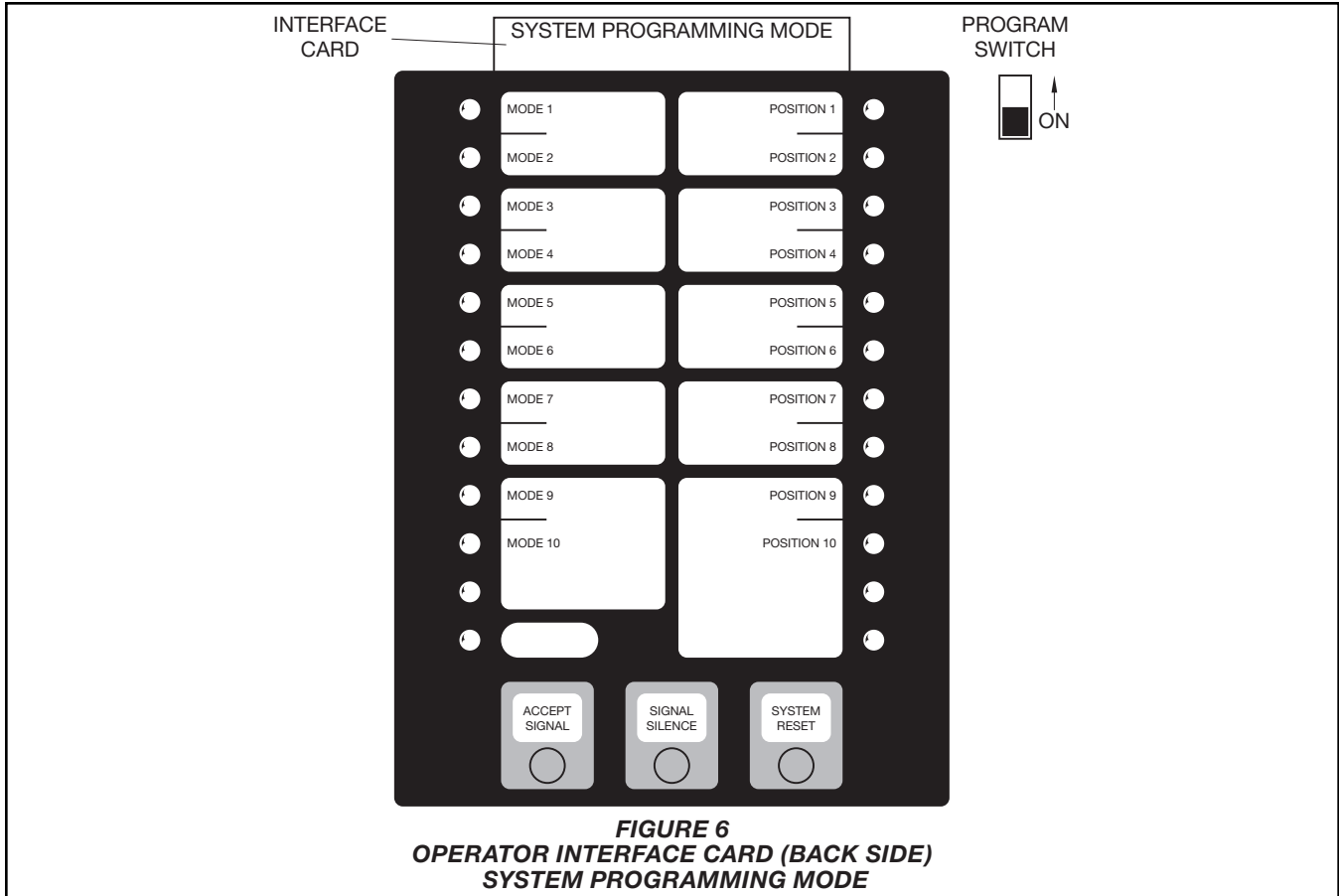

Step 2. Verify the Operator Interface Panel of the Electronic Control only indicates a green light for AC Power.

Step 3. Open and then close the Flow Test Valve. The Water Supply Gauge should drop to a previously noted residual pressure and then return to the normal static pressure.

Step 4. Perform a lamp test by pressing and holding the ACCEPT SIGNAL key for a duration of five seconds. Verify that all system LEDs are functioning.

System Trip Test

Step 1. Close the System Control Valve and accept the supervisory alarm at the Electronic Control by pressing the ACCEPT SIGNAL key.

Step 2. Partially open the Drain Valve to relieve air pressure. When the system trips (releases), completely open the Drain Valve.

- Note that the Electronic Control IDC1 indicates alarm when the air pressure gauge indicates nominally 8 psi.
- Note that the Electronic Control indicates released.
- Note that water is discharging from the drain line.

Step 3. Reset the Model RCP-1 Panel following the appropriate resetting instructions.

System Programming Mode Check
If a malfunction of the Electronic Control is suspected, verify the pre-programming of the panel as follows:

Step 1. With reference to Figure 6, remove the Operator Interface Card and reinsert it so that the System Programming Mode on its back side faces the front.

Step 2. Place the PROGRAM SWITCH (Figure 6) to the ON position and then momentarily press the ACCEPT SIGNAL key to accept the resulting programming mode trouble.

Step 3. Press the ACCEPT SIGNAL key to scroll through MODEs 1 to 10. Verify that POSITIONS 1 to 10 light up as follows:

- MODE 1: POSITION 6 for Dry Pipe
- MODE 2: POSITION 1 for Class B Initiating Circuit Style
- MODE 3: POSITION 1 for 0-Second Automatic Time Release Delay
- MODE 4: POSITION 1 for No RAC Cutout Timer
- MODE 5: POSITION 1 for 0 Second Manual Release Time Delay

- MODE 6: POSITION 1 for Immediate Abort -Release Time Delay
- MODE 7: POSITION 1 for Temporal NAC Coding
- MODE 8: POSITION 1 for ON Until Silenced NAC Operation
- MODE 9: POSITION 2 for Supervisory Latching
- MODE 10: POSITION 3 for Standard (LED-Piezo) Supervisory Notification

Step 4. If a position must be corrected for a given Mode number, press the SYSTEM RESET key to scroll through the positions. When at the correct position, press the ACCEPT SIGNAL key to confirm a selection and scroll to the next MODE number.

Step 5. Upon completing the programming check, place the PROGRAM SWITCH in the OFF position, and then return the Operator Interface card to its normal position.

NOTICE

Exercise care to ensure that all modes are restored to their proper settings.

Limited Warranty

For warranty terms and conditions, visit www.tyco-fire.com.

Ordering Procedure

Contact your local distributor for availability. When placing an order, indicate the full product name and Part Number (P/N).

Model RCP-1 Panel

Specify: (specify size), Model RCP-1 Residential Control Panel for a Residential Dry Pipe System, P/N (specify):

1 in.	52-310-2-601
1 1/2 in.	52-310-2-602

Separately Ordered Parts

Specify: Bezel for use with the Model RCP-1 Residential Control Panel, P/N 52-310-2-603

Panel Replacement Parts

Specify: 8.0 Amp Battery for use with the Model RCP-1 Residential Control Panel, quantity of 2, P/N 2656

Sprinklers

Refer to the specific technical data sheets describing Residential Sprinklers for use in dry pipe systems:

- 4.2K Sidewall/Recessed Sidewall Data Sheet TFP410
- 4.9K Pendent/Recessed Pendent Data Sheet TFP400
- 4.9K Domed Concealed Pendent Data Sheet TFP450
- 4.9K Dry-Type Recessed Pendent Data Sheet TFP460

CPVC Pipe & Fittings

Specify: Sprinkler Head Adapter Tee for use with Dry Pipe Systems, P/N 80259

For other CPVC pipe and fittings, refer to the CPVC Fire Sprinkler Products Installation Instructions and Technical Handbook, IH-1900.

TYCO SprinkFDT

For additional information or to purchase SprinkFDT software, visit www.sprinkcad.com.