



W27021-6-1

Fixed temperature type heat detector



Dimension (mm)

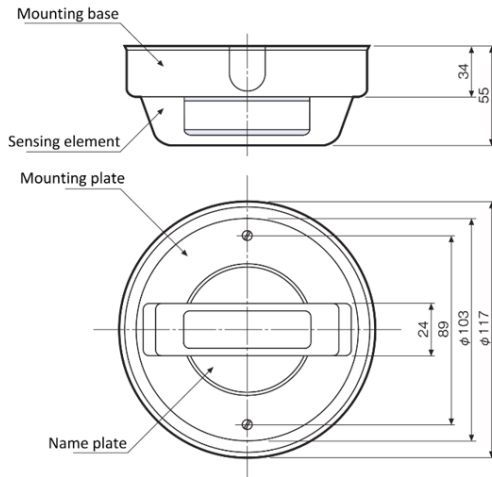

Model	Normal Operating Temperature	Operating Temperature Range
W27021-6-1-060	60 °C	- 10°C~40 °C
W27021-6-1-070	70 °C	- 10°C~50 °C
W27021-6-1-080	80 °C	- 10°C~60 °C
W27021-6-1-090	90 °C	- 10°C~70 °C
W27021-6-1-100	100 °C	- 10°C~80 °C
W27021-6-1-120	120 °C	- 10°C~100 °C
W27021-6-1-150	150 °C	- 10°C~130 °C

Application

The W27021-6 series is fixed temperature waterproof heat detector are suited for installation where high heat output fires are expected or in areas where ambient conditions would not allow use of other detection methods.

There are variation of detection temperatures such 60 °C, 70 °C, 80°C, 90°C, 100°C, 120°C and 150°C.

Specification

Type	Fixed Temperature Type Class 1. Waterproof Type
Model	W27021-6-1-Y 1: Surface Mount Type Y: Detection Temperature
Alarm Current	100mA @30Vdc
Material Cover Mount Plate Mount Base Sensor	SPCC t0.6 SPCC t1.0 SPCC t1.0 SUS321
Approx. cable Length	200mm
Approx. Weight	250g
Country of Origin	Japan
Approvals	JFEII
Made By	Fenwal Controls Of Japan, Ltd.

HOCHIKI ASIA PACIFIC PTE. LTD.

82 Ubi Ave 4 #06-02
Edward Boustead Centre, Singapore 408832
TEL: 65-6841-9728 | FAX: 65-6841-9781
URL : www.hochikiasiapacific.com

04/2020

HEAD OFFICE

10-43 Kamiosaki 2-Chome.
Shinagawa-Ku, Tokyo 141-8660 Japan
TEL: 81-(3)-3444-4116 | FAX: 81-(3)-3444-4167
URL : www.hochiki.co.jp

Specifications subject to change without notice